

---

---

---

---

---

**Concrete and Mortar Moisture Tester    HI-520-2**

The Kett logo consists of the word "Kett" in a white, serif font, centered within a dark gray square.

**Operating Manual**

## Safety Precautions

---

If the safety precautions for the concrete and mortar moisture tester are not observed, damage to property may result. Although product safety is fully considered, after carefully reading the precautions in this manual, please use the product in a proper manner.

- **Please observe the safety precautions.**

Please carefully read the precautions in the operating manual.

- **Do not use if broken.**

Do not use if broken.

- **Meaning of warning symbols.**

In order to prevent damage resulting from erroneously operating the equipment, the following symbols are indicated in the operating manual and on the product. The following are their meanings.

**Note**

Items which the user must follow in order to safely use the unit.

# CONTENTS

1. About the Model HI-520-2.....	4
2. Specifications .....	5
3. Part names .....	7
4. Display/Description of keys .....	8
5. Battery installation .....	9
6. Measurement method .....	10
7. Settings .....	12
8. Notes regarding use and handling of the HI-520-2 .....	27

## 1. About the Model HI-520-2

The HI-520-2 is a handy high-frequency moisture tester with integrated main unit and sensor section. Moisture content can be displayed directly simply by pressing the unit against the object to be measured.

The HI-520-2 also features alarm and hold functions which make it possible to confirm the results of measurements taken at locations which are not directly visible.

In addition, the HI-520-2 features a temperature compensation function which automatically eliminates the effects of temperature on measurement values, thus providing an all season capability.

The HI-520-2 is a valuable moisture content management tool, useful in a variety of applications in concrete manufacturing, water proofing and coating work in the construction and building industries.

### Measurement principles

When the concrete or mortar contains water, the conductivity will increase. This makes it possible to determine the moisture content by determining the relationship between moisture content and conductivity. The values obtained in this way are displayed as the measured moisture content.

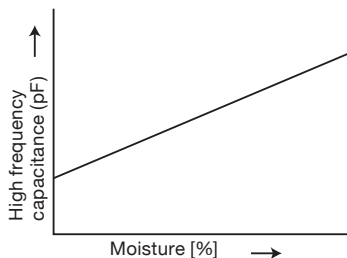

## 2. Specifications

Measurement method	High frequency capacitance (20MHz)
Measurement range	LWC (ALA : Artificial light weight aggregate concrete) ... 0 - 23% GYP (Gypsum board)..... 0 - 50% Concrete..... 0 - 12% ALC (Autoclaved lightweight concrete) .... 0 - 100% Mortar..... 0 - 15% CSB (Calcium silicate board) ..... 0 - 15% D mode..... 0 - 1999 S mode (only in S & D mode)..... 0 - 1100
Functions	Settings (5 types)
Precision	±0.5% (Concrete, Mortar)
Display	Digital (LCD)
Power supply	9V alkaline battery (006P) ×1
Power consumption	350 mW
Dimensions and weight	72(W)×146(D)×118(H) mm, approx. 0.39 kg
Accessories	9V alkaline battery (006P), soft case (with strap), operating manual
Options	Data logger software HDL-01 (with USB cable, a Windows PC with Excel installed)

This mode is displayed with a relative value of 0-1999, not a moisture content. The D mode measures the moisture content at relatively deeper point, and the S mode measures the moisture content at relatively shallower point. Refer to page 18 for further information.

## Applications/Modes and Functions

Applications/Modes	Temperature compensation	Alarm	Hold	Thick board selection	Data save/output	Registration of calibrations
Normal functions						
LWC (ALA)	○	○	○	—	—	—
GYP	○	○	○	○*1	—	—
Concrete	○	○	○	—	—	—
ALC	○	○	○	—	—	—
Mortar	○	○	○	—	—	—
CSB	○	○	○	○*1	—	—
D mode	—	—	○	—	—	—
Others						
S&D (D mode, S mode)	—	—	○	—	○*2	—
Make User Cal (0 - 7)	—	—	○	—	○*2	○*3

\*1 Thick board is selectable for GYP and CSB.

\*2 The data logger software, "HDL-01", (option) and a Windows PC with Excel installed are needed.

\*3 The use of data logger software, "HDL-01", (option) allows the users to easily make custom calibrations.

## 3. Part names

### <Main unit>

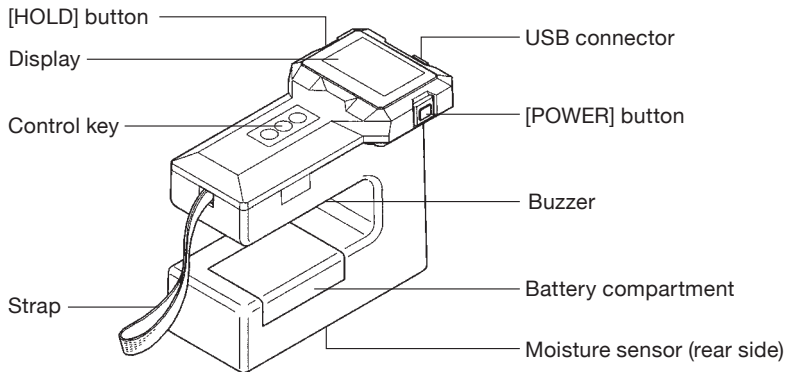

### <Accessories>

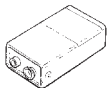

9V alkaline battery  
(006P) x1

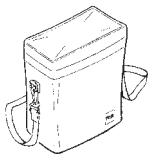

Soft case



Operating Manual

### (Option)

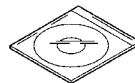

Data logger software  
HDL-01

## 4. Display / Description of key

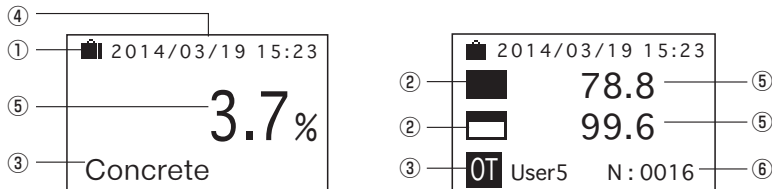

Item No.	Description
①	Indicates the remaining battery power. : Sufficient,  : Exhausted,  : Replacement required
②	Displayed when the calibration curve, one of the extension functions, is used. : Measured at a deeper point,  : Measured at a shallower point
③	Indicates the selected object to be measured and user calibrations. OT is displayed when the calibrations, one of the extension functions, are used.
④	Displays the date and time.
⑤	Displays the measured value. The moisture content (%) is displayed when a mode other than the D mode and S mode is selected. A value ranging from 0 to 1999 is displayed in the D mode, and a value ranging from 0 to 1100 is displayed in the S mode.
⑥	Indicates the data number after the data memory configuration. When GYP or CSB is selected, the selected board thickness will be indicated.
Main unit key	The use of the [*] key allows the user to determine settings and operations. The use of the [*] key allows the user to move to the target item or change values.



## 5. Battery installation

The unit is powered by one 9 V battery (006P alkaline).

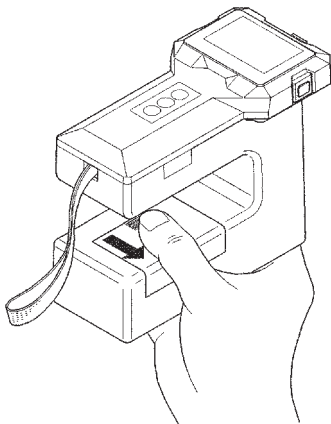

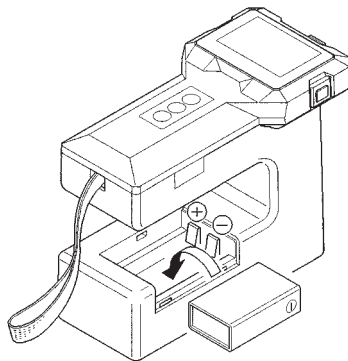

The unit is powered by one 9 V battery (006P alkaline).

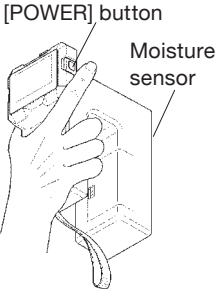

Replace the battery with new a new one. Pay attention to the ⊕ and ⊖ directions.

## 6. Measurement method

Step	Operation	Display	Description
1	<p>Start of measurement</p> 	<div data-bbox="516 264 762 412" style="border: 1px solid black; padding: 5px; margin-bottom: 10px;">Acquiring ver1.2 offset</div> <div data-bbox="628 416 643 540" style="text-align: center;">           • • • • •         </div> <div data-bbox="516 554 762 702" style="border: 1px solid black; padding: 5px;">  2014/03/19 15:23  Concrete         </div> <p>Eg.) Screen of measuring concrete</p>	<p>Press the power switch while the moisture sensor is pointed into the air.</p> <p><b>* Adjustment of the instrument is performed when the power is turned on. To perform correct measurements, be sure to turn on the power while the moisture sensor is directed into the air. Keep the moisture sensor being directed into the air until the measurement screen appears.</b></p> <p>The measurement screen appears approx. 3 seconds after a buzzer sounds.</p> <p><b>* If settings are changed, the display may change.</b></p>

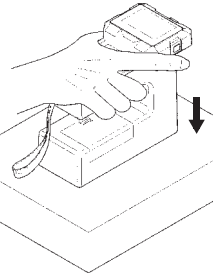
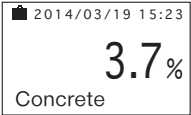
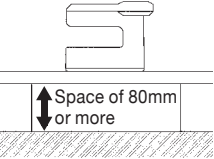
Step	Operation	Display	Description
2	<p>Measurement</p> 	 <p>Eg.) Measured results</p>	<p>While holding the main unit as shown in the drawing, slightly push the moisture sensor against the object to be measured, and the measured result is displayed.</p> <ul style="list-style-type: none"> <li>* <b>Moisture calibrations are made while holding the unit and slightly pushing it against the object to be measured. Refer to the drawing.</b></li> <li>* <b>The measured result is displayed while the moisture sensor is pushed against the object to be measured. If the hold button is pressed during measurement, the current measurement is retained and the result remains displayed even after separating the sensor from the object (hold state). To cancel the hold state, press the hold button again.</b></li> <li>* <b>If the moisture content exceeds the measurable range, the screen display over range.</b></li> </ul>
			<p>(For thin board measurement) When the object to be measured is 40 mm or less in thickness (such as GYP or CSB), keep a space of at least 80 mm below the measurement point (as shown on the drawing).</p>
3	Completion of measurement		When measurements are completed, turn off the power.

## 7. Settings

Settings from 1 through 5 can be performed by pressing the  key on the measurement screen.

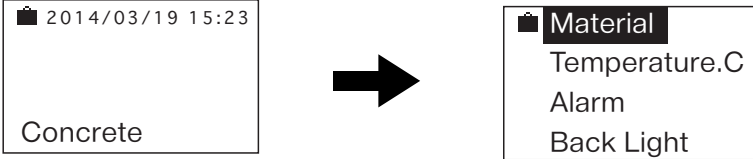

1	Material selection	(P.13)	4	Backlight brightness	(P.16)
2	Temperature compensation	(P.14)	5	Extension functions	(P.17)
3	Alarm setting	(P.15)	6	Return (not included in settings)	

- \* Refer to each indicated page for the functions or meanings of each pattern.*
- \* Although 4 items are displayed on the screen, screen, all six items may be displayed by scrolling the page with use of the ▲ or ▼ key.*
- \* Once these settings are performed, the settings contents are stored in memory, even when the instrument is powered off.*
- \* To use the S mode, use the S & D mode, one of the extension functions. (See page 18.)*

# 1 Material selection [Material]

---

Seven types of factory calibrated products may be selected.

- (1) Press the  key on the measurement screen, and the screen changes to the setting screen.

Use the ▲ or ▼ key to select “**Material**” and press the  key.

- (2) Use the ▲ or ▼ key to select a material from 7 calibrations.

- ① D mode
- ② ALA concrete (LWC)
- ③ GYP (Gypsum board : Thickness: 9.5mm, 12.5mm, 15.0mm)
- ④ Concrete
- ⑤ ALC
- ⑥ Mortar
- ⑦ CSB (Autoclaved lightweight concrete: Thickness: 5mm, 6mm, 7mm, 8mm, 10mm or more)

*\* When ③ or ⑦ material is selected, select a thickness from the parentheses.*

- (3) Press the  key to confirm the setting and return to the measurement screen.

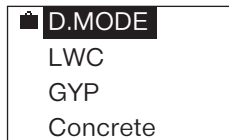



## 2 Temperature compensation [Temperature.C]

---

This setting cannot be performed when the D mode is selected or the custom calibrations are used.

Automatic temperature correction is performed on the basis of the temperature sensed by the temperature sensor in the measuring instrument. When a temperature difference between the measuring instrument and the object to be measured is significant, the temperature can be manually specified.

- (1) Press the  key on the measurement screen, and the screen changes to the setting screen.  
Use the ▲ or ▼ key to select “**Temperature.C**” and press the  key.
- (2) Use the ▲ or ▼ key to select “**Manual**” (–10 to 70 °C).  
When want to select automatic correction, push ▲ key until exceed 70 °C.
- (3) Press the  key to confirm the setting and return to the measurement screen.

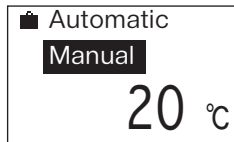
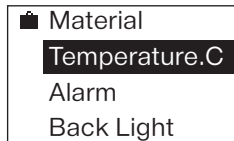



### 3 Alarm setting [Alarm]

---

This setting cannot be performed when the D mode is selected or the custom calibrations are used.

The upper limit of moisture content can be specified. When the moisture content exceeds the specified value, a buzzer sounds.

- (1) Press the  key on the measurement screen, and the screen changes to the setting screen.  
Use the ▲ or ▼ key to select “**Alarm**” and press the  key.
- (2) Use the ▲ or ▼ key to select “**On**” (2 to 40%). When want to be alarm off, push ▲ key until exceed 40%.
- (3) Press the  key to confirm the setting and return to the measurement screen.

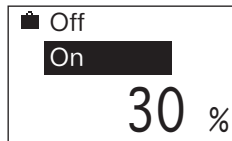
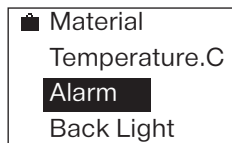

## 4 Backlight brightness [Back Light]

---

The brightness of the backlight can be selected (Off, Moderate, or Bright).

The backlight is useful for measurement or key operation in the dark.

- (1) Press the  key on the measurement screen, and the screen changes to the setting screen.

Use the ▲ or ▼ key to select “**Back Light**” and press the  key.

- (2) Use the ▲ or ▼ key to select the brightness of the backlight.

- (3) Press the  key to confirm the setting and return to the measurement screen.

*\* The use of backlight decreases battery life.*

*\* If no operation is performed for approximately 10 seconds, the backlight turns off for battery saving. When an operation is performed, the backlight turns on again.*

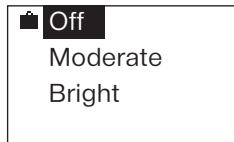
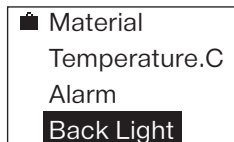



## 5 Extension functions [Others]

---

(1) Press the  key on the measurement screen, and the screen changes to the setting screen.

Use the ▲ or ▼ key to select “**Others**” and press the  key.

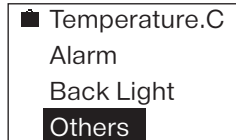

(2) There are 6 extension functions as listed below : Use the ▲ or ▼ key to select a function.

①	Select User Cal	(P.17)
②	Make User Cal	(P.18)
③	Data Memory	(P.21)
④	Data Output	(P.22)
⑤	Clear All Data	(P.23)
⑥	Date and Time	(P.24)
⑦	Return (not included in extension functions)	

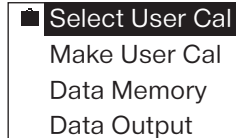

**\* Refer to each indicated page for the functions or meanings of each pattern. “⑦ Return” is not included in the extension functions.**

## 5 Others [① Select User Cal]

(1) Select “**Select User Cal**” on the extension function and press the  key.

(2) Use the ▲ or ▼ key to select from “**User0**” through “**User7**” or “**S & D**” and press the  key.

*\* When the user calibration has not been completed, the calibration cannot be selected. Refer to “② Make User Cal” on page 19 for how to set the calibrations.*

*\* “D.MODE” and “S.MODE” are displayed at the same time for the S & D mode.*

(3) Press the  key to return to the measurement screen on the calibration selected.

### • Description on D mode/S mode

The D mode is displayed not with the moisture content but with the value of 0 to 1999, which correlates to the high-frequency capacitance signal. The relationship between moisture contents and the D mode is shown as the graph at right. Measured values equivalent to the D.MODE of HI-520 will be provided.

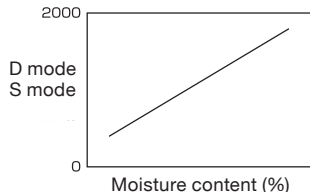
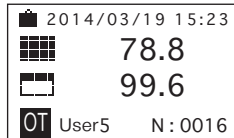
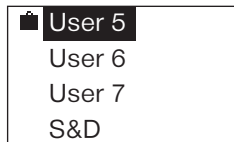
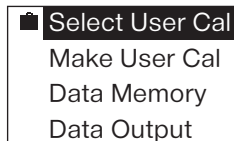

The S mode can also provide values correlated with the high-frequency capacitance signal, but the measurement depth is different between the D mode and S mode. The D mode measures the moisture content at relatively deeper point, and on the other hand, the S mode measures the moisture content at relatively shallower point.

## 5 Others [② Make User Cal]

---

### • What is a user calibration?

The calibrations on this unit have been made on the basis of the relationship between high-frequency capacitances and moisture contents. The D mode is correlated with high-frequency capacitance. Understanding the relations between the moisture content of the object to be measured and the D mode value provides relationship between the high-frequency signal and the moisture content. Custom calibrations may be created by user to allow the HI520-02 to be used for more than just the factory calibrations. To create the user calibrations, prepare multiple samples (2 to 8 pieces) with different moisture contents and record the D mode values and corresponding moisture content obtained by a different moisture method (see Fig. 1).

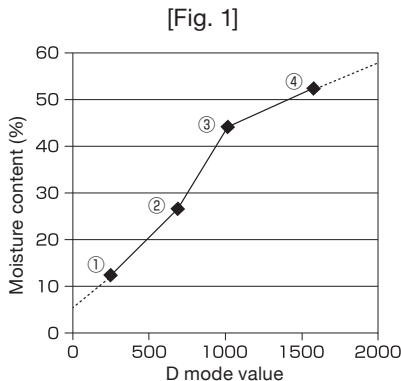

\* *At least two samples and up to eight samples are needed. Arrange the results in ascending order of the D mode values as shown in the [Table 1]. Each point is referred to as a zigzag point, and connect zigzag points with a straight line. For points less than the minimum point and more than the maximum point of the calibrations, a prolongation of the adjacent line is applied. In the case of the graph at right, the prolongation of ①-② is applied to the part below ①, and the prolongation of ③-④ is applied to the part above ④.*



Table 1

	D mode	Moisture value
①	246	12.4
②	688	26.7
③	1015	44.2
④	1578	52.3

\* *The user calibrations can also be created in the S mode as well as the D mode.*





\* *The use of data logger software, “HDL-01”, (option) allows users to simplify user calibrations.*

## Eg.) When the D mode of 246 and the moisture content of 12.4 are entered into user calibration number 1:

- (1) Select “**Make User Cal**” on the extension function and press the  key.
- (2) Use the ▲ or ▼ key to select “**User Cal. No 1**” and press the  key.

■	Select User Cal
	<b>Make User Cal</b>
	Data Memory
	Data Output

■	<b>User Cal. No</b>	1
	Mode	D.MODE
		S.MODE
		S&D

- (3) Use the ▲ or ▼ key to select “**D.MODE**” and press the  key.
- (4) Use the ▲ or ▼ key to select “**D.MODE 246**” and press the  key.
- (5) Use the ▲ or ▼ key to select “**Moisture 12.4**” and press the  key.
- (6) Press “**Continue**” and press the  key.  
Repeat the steps from (4) through (6) to enter the data of ② and the other samples in [Table 1].
- (7) After entering all the data, use the ▲ or ▼ key to select “**Exit**”. When the  key is pressed, the user calibration is completed.

*\* To use the unit in the S & D mode, perform value entry of the S mode after value entry of the D mode. The value entry method is the same as the steps from (4) through (6).*

	User Cal. No	1
	Mode	<b>D.MODE</b>
		S.MODE
		S&D

	Point	0
	<b>D.MODE</b>	246
	Moisture	

	Point	0
	D.MODE	246
	<b>Moisture</b>	12.4

	Point	1
	<b>Continue</b>	

	Point	1
	<b>Continue</b>	
	Exit	

## 5 Others [③ Data Memory]

The measured data can be stored only when a user calibration has been completed.

When a factory calibration is selected, the measured data cannot be stored.

The measured data can be stored in the internal memory.

(1) Select “**Data Memory**” on the extension function screen and press the  key.

(2) Use the ▲ or ▼ key to select “**On**”.

(3) Press the  key to confirm the setting and return to the measurement screen.

*\* When the data is not stored, select “Off” and press the  key to return to the measurement screen.*

*\* Pressing the hold button during measurement in sequential order (1-1000). When the data No. exceeds 1000, the number goes back to No. 1, and the data is overwritten on in order from data No. 1.*

*\* To view the stored data, data output is needed. (See “④ Data Output” on page 23.)*





## 5 Others [④ Data Output]

---

The data stored in the internal memory can be downloaded to a PC.

*\* To download the data to a PC, the data logger software, “HDL-01”, (option) is needed. Use a Windows PC with Excel installed.*

- (1) Select “**Data Output**” on the extension function screen and press the  key.
- (2) Use the ▲ or ▼ key to select “**Transmit**”.
- (3) Press the  key to send the data to the PC and return to the measurement screen.

*\* When the data output is not necessary, select “Return” and press the  key to return to the measurement screen.*



Select User Cal  
Make User Cal  
Data Memory  
**Data Output**





**Transmit**  
Return

## 5 Others [⑤ Clear All Data]

---

All the data stored in the internal memory can be deleted.

- (1) Select “**Clear All Data**” on the extension function screen and press the  key.
- (2) Select “**Clear All Data**” again.
- (3) Press the  key to delete all the stored data and return to the measurement screen.

*\* When the data is not deleted, select “Return” and press the  key to return to the measurement screen.*

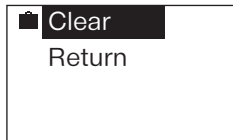
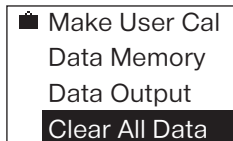





## 5 Others [⑥ Date and Time]

---

The date and time can be set.

- (1) Select “**Date and Time**” on the extension function screen and press the  key.
- (2) Use the ▲ or ▼ key to set the year and press the  key.
- (3) Set the month, day, hour, and minute in this order in the same way.
- (4) Press the  key after setting the minute to return to the measurement screen.

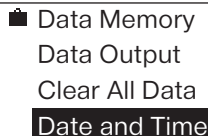

☑ Data Memory  
Data Output  
Clear All Data  
**Date and Time**





☑  
Date 2014/03/20  
Time 15/23

## Language switching

---

The language displayed can be changed.

- (1) Turn ON the power while pressing  key at power OFF.
- (2) Select “**Language**” on the screen and press the  key.
- (3) Use the ▲ or ▼ key to select the language and press the  key.
- (4) The language is changed, and the instrument returned automatically to the measurement screen.

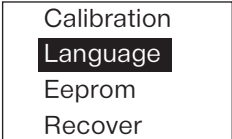

Calibration  
**Language**  
Eeprom  
Recover

## 8. Notes regarding use and handling of the HI-520-2

- When making measurements, hold the unit so that the sensor is in even contact with the surface to be measured. It is best if the surface being measured is flat.
- The surface area of the object being measured must be greater than the surface area of the sensor (130 x 55mm).
- Reproducing part or all of this manual without permission is prohibited.
- The contents of this manual are subject to change without notice.
- The appearances, screens and other parts of the product and accessories displayed in this manual may differ from the actual ones, but the operations and functions are not affected.
- All efforts have been made to ensure the contents of this manual are accurate. However, if you notice any items in this manual to be unclear, incorrect, omitted or have any other problems, please contact us.
- Be aware that we are not liable for the effects resulting from operations according to this manual regardless of the items above.

## Caution

- It is strictly prohibited to transfer part or all of this manual without permission.
- The contents of this manual are subject to change without notice.
- The appearances, screens, etc. of the product and accessories displayed on this manual may differ from the actual ones, however, operations and functions are not affected.
- All efforts have been made to ensure the contents of this manual are accurate. However, if you notice any part to be unclear, incorrect, omitted, or the like in this manual, please contact us.
- Be aware that we are not liable for the effects resulting from operations according to this manual regardless of the items above.

The logo for Kett, featuring the word "Kett" in a white, sans-serif font on a dark grey square background.

## ***KETT ELECTRIC LABORATORY***

1-8-1 Minami-Magome Ota-Ku, Tokyo 143-8507 Japan

Tel. +81-3-3776-1121 Fax. +81-3-3772-3001

URL <http://www.kett.co.jp/> E-mail [overseas@kett.co.jp](mailto:overseas@kett.co.jp)